

# FUMEX

# CV



## ***A flexible modular filter for particles and gas***

Fumex modular filter, CV with its sturdy profile, gives the possibility to satisfy the need of several functions in one product.

The filter is, in its basic version, dimensioned to handle fumes from one work station, but several filters can be parallel connected to serve several work stations in the same system.

Maximum flexibility from a simple disposable filter to a solution with cleaning via compressed air, but also the possibility to combine particle- and gas filtration in the same unit or a gas filtration only.

The filter unit is wall mounted and the sturdy profile makes the installation easy, but also simplifies necessary service and maintenance.

*The Fumex range also includes fans, accessories, automatic control and local extraction for filters*

**FILTER**  
**Pure advantage**

## Cleanable filter unit

Cleanable filtration unit with a 14m<sup>2</sup> filter surface in polyester. The filter cartridge is cleaned via compressed air.

## Pre-filter CVM

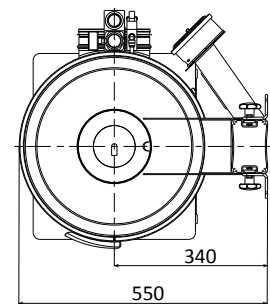
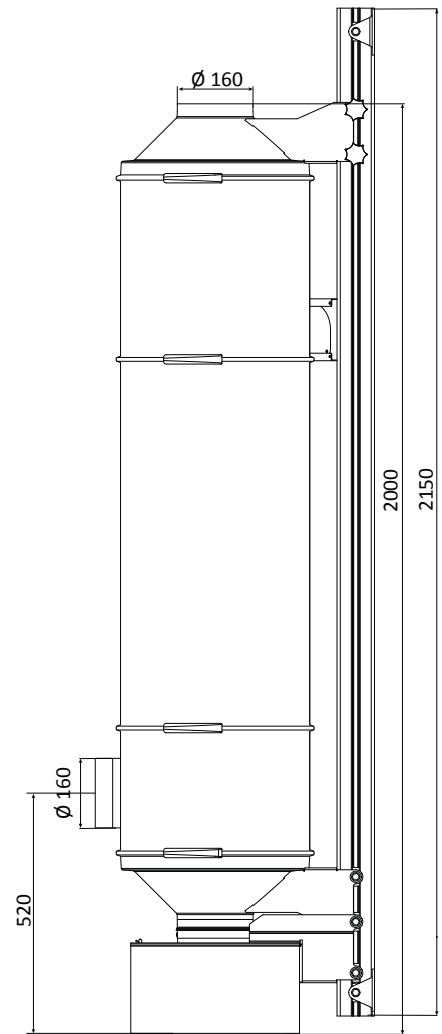
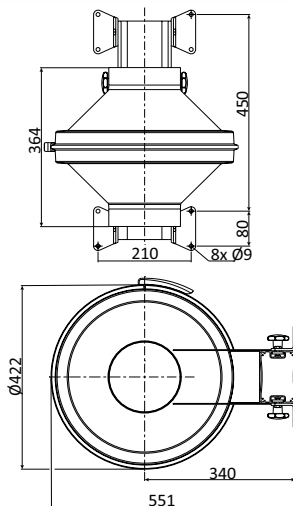

(mm)

## CVP

Filter with manual compressed air cleaning, with an external pre-filter, CVM, including a metal mesh. For applications with large amounts of dry particles, e.g. dust- and welding smoke in mechanical industries. Delivered with a filter cartridge, profile, two connections and requisite details for compressed air cleaning. It also includes an analogue pressure gauge that shows the pressure drop over the filter cartridge. The lower duct connection is 180° adjustable.

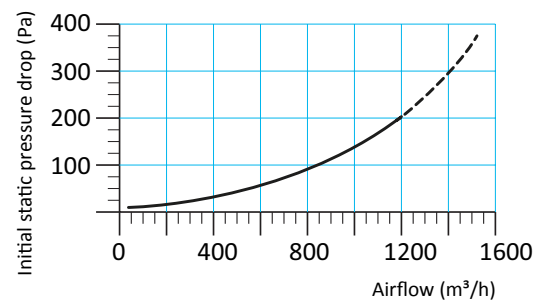

### Specifications CVP

Filter casing:	Powder coated steel	Type of filter cartridge:	CFS 149
Profile:	Anodised aluminium	Material:	Polyester
Profile brackets:	Powder coated steel	Filter efficiency according to EN-60335-2-69:	99,9 %
Total weight:	53 kg	Dust class:	M(BIA)
Max. temperature processed air:	60 °C	Filter area:	14,9 m <sup>2</sup>
Maximal negative pressure upper cartridge:	1800 Pa		

## How the CVP works

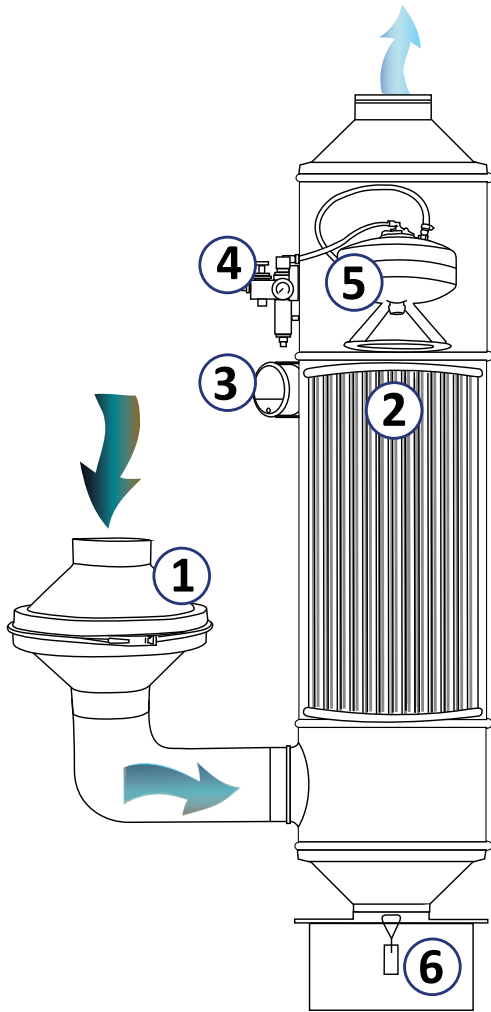

### Cleanable filter type CVP

With manual compressed air cleaning the filter has a long lifetime, even when there is a high load over the filter cartridge.

1. To protect the filter cartridge from large particles, a pre-filter (CVM) is placed on the inlet channel. The pre-filter can be mounted either on the wall or directly in the duct.

A vertical position of the filter simplifies a change of the filter cartridge.

2. Filter cartridge in polyester, with BIA filter class M, 14m<sup>2</sup> filter area.
3. Pressure gauge that shows the pressure drop over the filter cartridge. The initial pressure over the filter cartridge is 100-200 Pa, depending on the airflow. When the pressure drop has increased to 800-1000 Pa the filter cartridge should be cleaned via the pulse valve. The most efficient cleaning is done with the fan shut off and with 3 to 5 pulses. The filter cartridge can also be cleaned with the fan on. Indication for filter change.
4. Multi-function valve for compressed air:
  - Shut off valve and evacuation valve.
  - Pressure release function to set correct cleaning pressure 3,5 Bar.
  - Pressure gauge that shows the set cleaning pressure value.
  - Pulse valve to manually clean the filter cartridge.
5. Tank for compressed air with integrated pulse nozzle.
6. Below the inlet for polluted air, a bin for collection of dust is placed.

## Disposable filter in steel casing

Filter unit with several options for filter cartridges (particle and gas). The cartridge is placed inside a powder coated steel casing. The filter cartridge and steel casing is placed between two gables on an anodised aluminium profile. Delivered completely with filter cartridge, profile and two connections.

For an easy filter cartridge change, the top gable is released and is lifted on the profile.

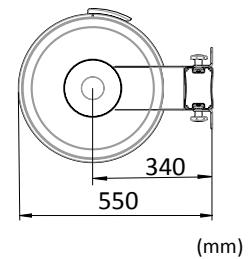
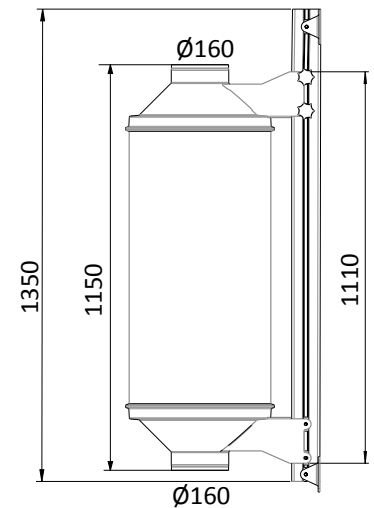

## Particle filter

### CVS

Filter for dry particles, e.g. dust- and welding smoke in mechanical industries. As a protection against big particles a pre-filter with a metal mesh is included inside the unit.

### CVH

HEPA 13 filter with a very high level of separation. The filters are designed to create a clean zone, which is demanded when manufacturing e.g. pharmaceuticals and food. As a protection against big particles a pre-filter with a metal mesh is included inside the unit.

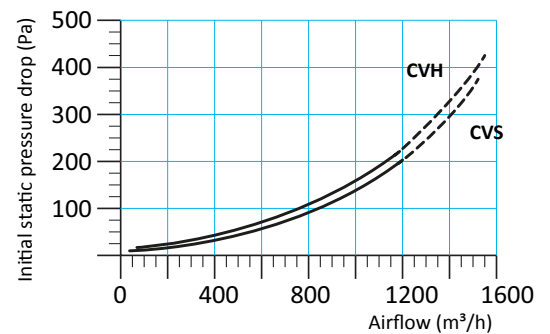

### Specifications CVS/CVH

Filter casing:	Powder coated steel	Type of filter cartridge:	<b>CVS</b> CFS 149	<b>CVH</b> CFH 149
Profile:	Anodised aluminium	Material:	Polyester	Fiberglass
Profile brackets:	Powder coated steel	Filter efficiency according		
Total weight:	27 kg	-to EN-60335-2-69:	99,9 %	99,95 %
Max. temp. processed air:	60 °C	-to DOP 0,3 µm:		
Maximal negative pressure		Dust class:	M(BIA)	
upper cartridge:	1800 Pa	Filter area:	14,9 m <sup>2</sup>	14,9m <sup>2</sup>

## Gas filter

### CVC

The cartridge is placed inside a powder coated steel casing. Contains a standard active carbon that is suitable for absorption of odours, gases, smoke and VOC:s: e.g. toluene and methyl ethyl ketone.

To obtain the best result it's important to let the contact time between the carbon and the substance to be as long as possible. Therefore we recommend that the airflow over the filter module should not be higher than 500 m<sup>3</sup>/h. For a greater airflow two or more filter modules can be placed side by side.

If the polluted air also contains particles, it's advisable to place a particle filter before the carbon filter cartridge.

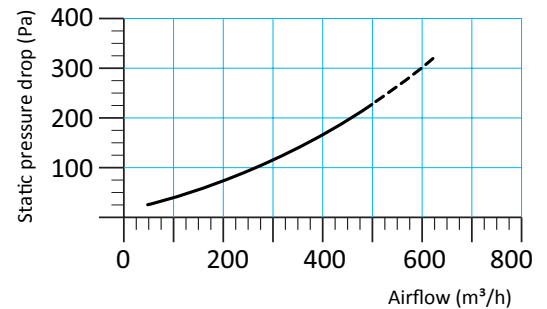

#### Specifications CVC

Filter casing:	Powder coated steel	Type of filter cartridge:	CFC 500
Profile:	Anodised aluminium	Material:	Active carbon
Profile brackets:	Powder coated steel	Weight:	16 kg
Total weight:	44 kg	Mesh size:	4 mm
Recommended temperature:	20 °C	CTC absorption (W/W):	65 %
Max airflow:	500 m <sup>3</sup> /h	Surface area (BET):	1050 m <sup>2</sup> /gr
		Apparent density:	0,49 kg/dm <sup>3</sup>

### CVCC BiOn

The cartridge is placed inside a powder coated steel casing. Contains an impregnated active carbon that is suitable for absorption of formaldehyde and ammonia.

To obtain best result, it's important to let the contact time between the carbon and the substance to be as long as possible. Therefore we recommend that the airflow over the filter module should not be higher than 500 m<sup>3</sup>/h. For a greater airflow two or more filter modules can be placed side by side. If the polluted air also contains particles, it's advisable to place a particle filter before the carbon filter cartridges.

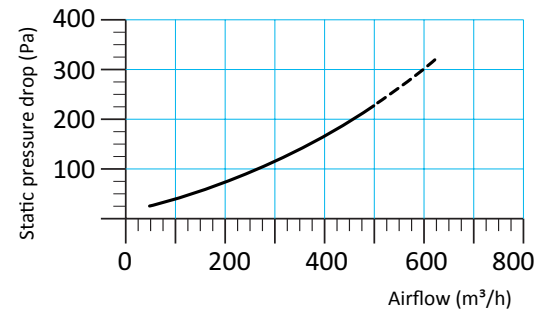

#### Specifications CVCC BiOn

Filter casing:	Powder coated steel	Material:	Impregnated active carbon
Profile:	Anodised aluminium	Weight:	16 kg
Profile brackets:	Powder coated steel	Mesh size:	3 mm
Total weight:	46 kg	CTC absorption (W/W):	45 %
Recommended temperature:	20 °C	Surface area (BET):	900 m <sup>2</sup> /gr
Max airflow:	500 m <sup>3</sup> /h	Apparent density:	0,75 kg/dm <sup>3</sup>
Type of filter cartridge:	CFCC 500 BiOn	Impregnation KMnO <sub>4</sub> :	11 %

## Disposable filter

The filter cartridge is placed between two gables on an anodised aluminium profile.

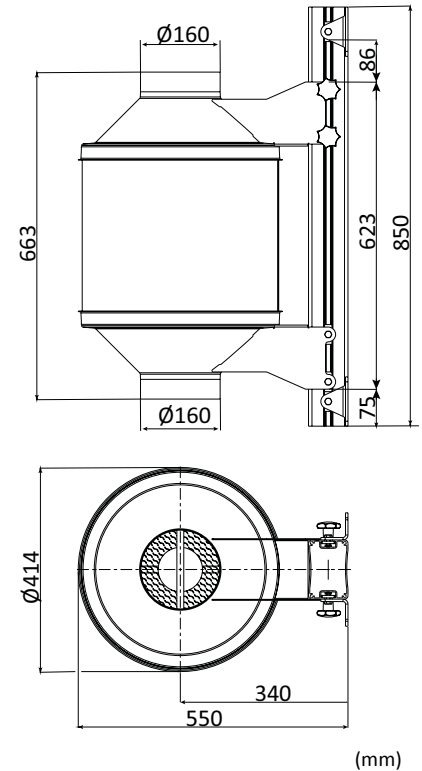

## CVD

The filter cartridge has a surface area of 22 m<sup>2</sup> in BIA class M. As a protection against big particles a pre-filter with a metal mesh is included inside the unit. The filter cartridge is placed between two gables on an anodised aluminium profile. Delivered with a filter cartridge, profile and two connections.

For an easy filter cartridge change, the top gable is released and is lifted on the profile.

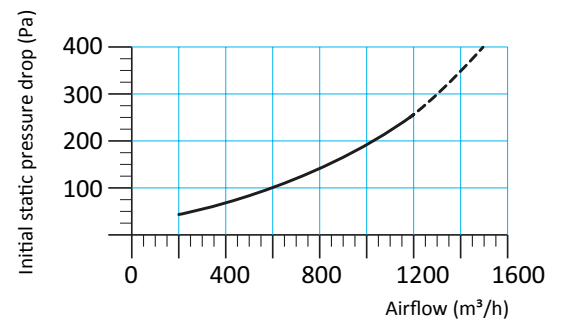

### Specifications CVD

Filter casing:	Powder coated steel/paperboard	Type of filter cartridge:	CFD 220
Profile:	Anodised aluminium	Material:	Cellulose
Profile brackets:	Powder coated steel	Filter efficiency according to EN-60335-2-69:	99 %
Total weight:	16 kg	Dust class:	M(BIA)
Max. temp. processed air:	60 °C	Filter area:	22 m <sup>2</sup>
Maximal negative pressure upper cartridge:	1800 Pa		

## Accessories

### FB 110

The high efficiency meets the requirements of ErP for 2015.

For welding applications, fan FB 110 will provide an airflow of approximately 1000 m<sup>3</sup>/h and have a power output of 1,1 kW, single phase or three-phase.



<b>FB 110-3</b>	3- phase (230/400 V)	4,0/2,3 A
<b>FB 110-1</b>	1- phase (230 V)	6,7 A

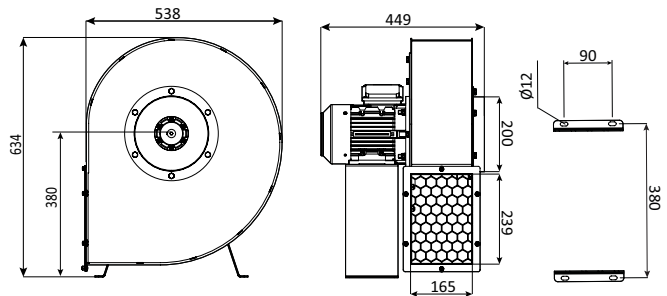
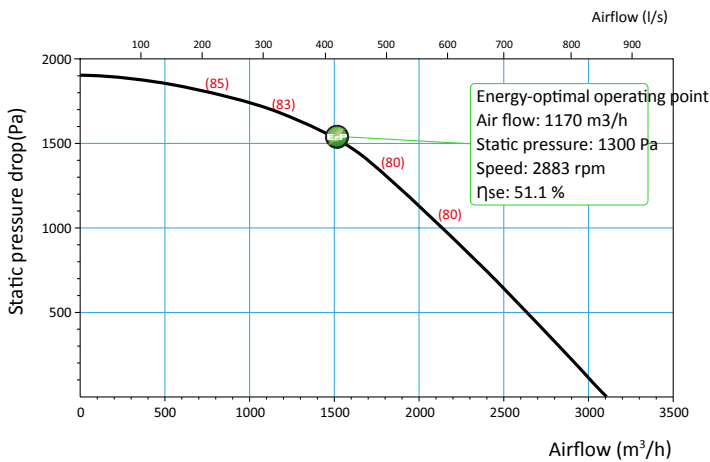

### CV R200-160

Reducer to FB. To be mounted on the inlet of the FB 110 for a connection to the CV filter.

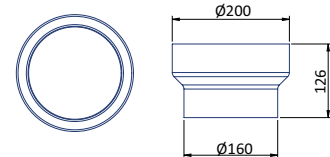

### CV PR

Bracket to be mounted on wall to get the PR extractor to be lined up with the CV filter.

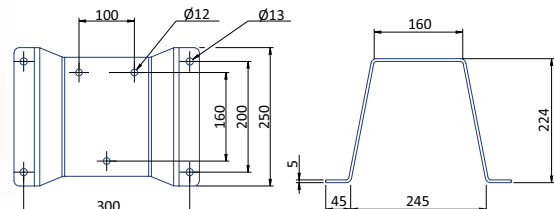

### CV G

Analogue pressure gauge that shows the pressure drop over the filter cartridge. Delivered in a set with hose, connections and a bracket so it can be mounted on the aluminium profile.



*Installation example*

