



CVP

STD/W3

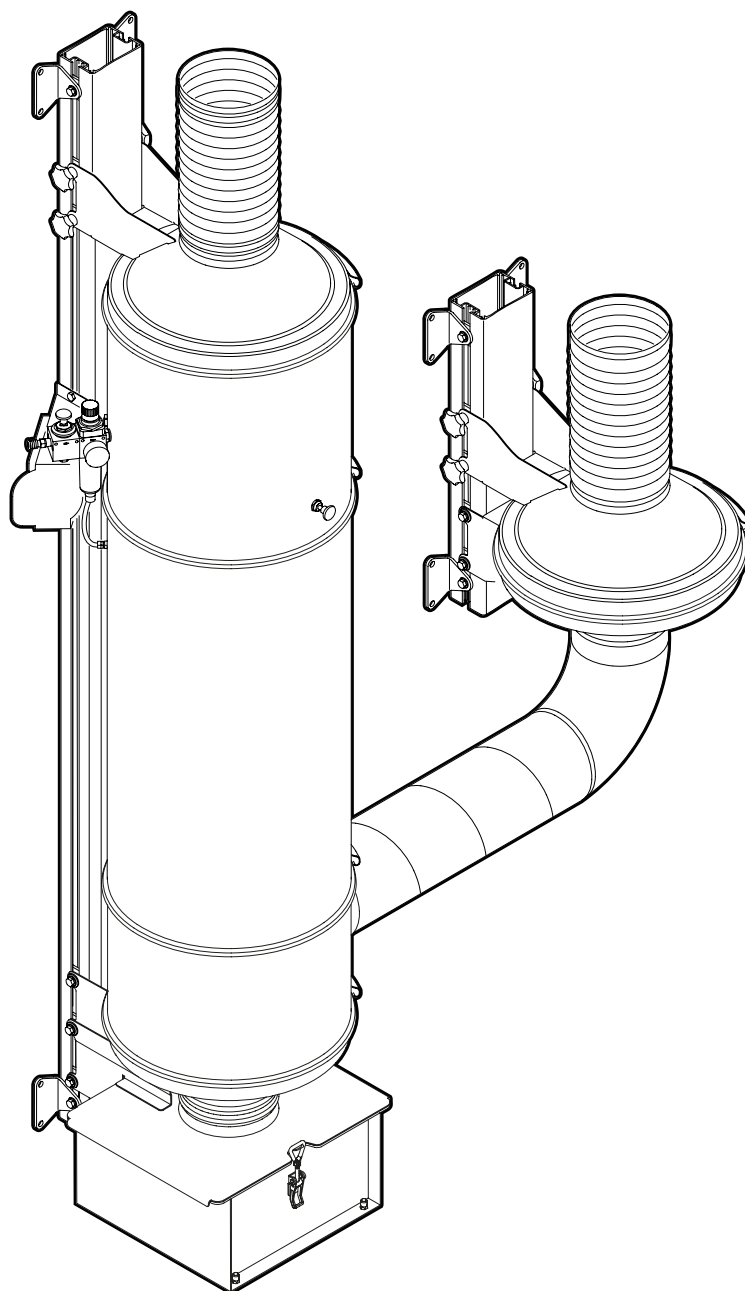

TABLE OF CONTENTS

1 Introduction	3	6 Operation	11
1.1 The manual	3	6.1 Control panel	11
1.2 Declaration	3	6.2 Manual cleaning	11
1.3 Warranty	3	7 Troubleshooting	12
1.4 Manufacturer	3	7.1 Troubleshooting guide	12
2 Safety	4	8 Maintenance	13
2.1 General	4	8.1 Cleaning	13
2.2 Warning levels (on product)	4	8.2 Maintenance schedule	13
2.3 Safety signs	4	8.3 Replacing the filter cartridge	14
2.4 Protective equipment	4	8.3.1 Filter unit CVP STD	14
2.5 General warnings & information	4	8.3.2 Filter unit CVP W3	15
3 Product Description	5	8.4 Emptying the dust collector	16
3.1 Serial number & product name	5	8.4.1 Filter unit CVP STD	16
3.2 Labels and safety signs	5	8.4.2 Filter unit CVP W3	16
3.3 Areas of Use	6	8.5 Replacing/cleaning the Prefilter CVM	17
3.3.1 Variants	6	8.5.1 Filter unit CVP STD	17
3.4 Design	6	8.5.2 Filter unit CVP W3	17
3.5 Function	7	8.6 Compressed air	18
3.5.1 Filter unit CVP STD	7	8.6.1 Evacuate pressure tank	18
3.5.2 Filter unit CVP W3	7	8.6.2 Evacuate water separator	18
4 Preparation for use	8	9 Decommissioning	18
4.1 Transport & storage	8	9.1 Final decommissioning/disassembly/disposal	18
4.2 Electrical equipment	8	10 Technical information	19
4.3 Assembly	8	10.1 Dimensional drawing (mm)	19
4.3.1 Unpacking	8	10.2 Technical data	19
4.3.2 Service area	8	10.3 Circuit diagram pneumatics	20
4.4 Installation	9	10.4 Circuit diagram electronics	20
4.4.1 Duct dimensioning	9	10.4.1 Filterunit CVP W3	20
4.4.2 Pneumatics	9	10.5 Exploded-view drawing	21
4.4.3 Electronics	9	11 Accessories & Spare Parts	22
5 Commissioning	10	12 Notes	23
5.1 Before start-up	10		
5.2 Start-up	10		
5.3 Pre-coating	11		

Foreword

FUMEX operates in the environmental technology sector and specialises in extraction arms, fans, and filters for all work environments. The company strives to create work environments free from airborne contaminants.

Our products are manufactured using modern methods and undergo extensive quality inspections. The products comply with applicable safety and environmental requirements.

If you have any questions about FUMEX or our products, please contact your dealer or the FUMEX sales department.

1 Introduction

1.1 The manual

To ensure your knowledge of the product, you must read this manual before use.

The information in this manual is intended to facilitate the installation, operation, maintenance, troubleshooting, and repair of the product. The manual also provides the user with a technical understanding and basic safety instructions to minimise risks when working with the product, as well as to increase the product's service life.

The manual should be considered a part of the product and should always be accessible and in close proximity to the product.

The following symbols are referred to in the manual:



Safety instructions (applicable to people or machinery) that must always be adhered to. Risk of death or risk of personal injury or damage to property.



Recommendations which convey important information for an optimally functioning product.



Important information for equipment according to ISO 15012-1, safety when welding.

1.2 Declaration

CE The product is CE certified and conforms to all applicable provisions in directives and standards as follows:

- Machinery Directive 2006/42/EC
- EMC Directive 2014/30/EU
- Safety of Machinery EN ISO 12100: 2010
- Electrical Equipment of Machines EN 60204-1

For a full EC Declaration, please contact FUMEX.

1.3 Warranty

To preserve the validity of the warranty, it is forbidden to modify or re-engineer the product during the warranty period without first obtaining prior approval from FUMEX. This is also applicable to any spare parts used which do not correspond to the manufacturer's specifications.

Damage caused by improper use of the product will result in:

- the warranty being voided
- the EC Declaration and CE certification being voided.

The warranty period is one year from the date of purchase and covers the product and its constituent parts. All manufacturing defects are covered by the warranty. FUMEX replaces defective parts in accordance with NL 17.

FUMEX is not liable for any consequential or incidental damage, or any loss of income as a result of or in connection with the warranty case.

The onus is on the buyer to select the appropriate product for the intended use. Any modifications to the FUMEX product or its intended use will void the warranty.

1.4 Manufacturer

FUMEX AB
Tel. no.: +46 910-361 80
Email: info@fumex.se

Verkstadsvägen 2
SE-931 61 Skellefteå
Sweden



2 Safety

2.1 General

The product is safe to use. It is designed in such a way that hazardous parts are only located in inaccessible areas. Even so, if the product is not used correctly or as intended, it may be hazardous to the user or cause damage to the product. The user should therefore be informed and trained to handle the product's safety features.

2.2 Warning levels (on product)

Safety signs on FUMEX products make use of colour codes and signal words in accordance with ISO 3864-2.

-  **Red (DANGER)** - used to indicate an imminently dangerous situation which, if not avoided, will result in death or serious personal injury.
-  **Orange (WARNING)** - used to indicate a potentially dangerous situation which, if not avoided, may result in death or serious personal injury.
-  **Yellow (CAUTION)** - used to indicate a potentially dangerous situation which, if not avoided, may result in moderate or minor personal injury.

2.3 Safety signs

Refer to **3.2 Labels and safety signs**.

2.4 Protective equipment

No special protective equipment is required to use the product. However, personal protective equipment such as safety glasses, respiratory protection, and safety gloves must be worn when replacing filter cartridges and emptying the dust collector.

2.5 General warnings & information



The product must not be modified.
 Power to the machine must be switched off prior to maintenance, repair, or adjustment.
 The machine may only be used in perfect technical condition and according to its intended use as described in Section **3.3 Areas of Use**. Faults that may jeopardise safety must be rectified immediately.

Work on the machine's electrical equipment may only be carried out by a licenced electrician in accordance with applicable local electrical safety regulations.

There is always risk associated with the machine's moving parts (e.g. cutting, clamping or gripping points).

In the event of fire, hatches or service doors must not be opened.

Under no circumstances may water be used to extinguish/cool in the event of fire or heat build-up. A powder extinguisher or other suitable extinguisher must be used instead.

The machine must not be used in a potentially explosive atmosphere or to extract dust and gases in explosive concentrations.

All work on the machine must be carried out by certified and authorised personnel.

For maintenance work where contact with dust occurs, personal protective equipment such as safety glasses, respiratory protection, and safety gloves must be worn.



The machine should only be used by personnel with good knowledge of the machine and its operation.

In case of change of the products are of use, always consult the manufacturer for risk minimisation and product optimisation.

Waste disposal must be carried out in accordance with the relevant national regulations.

3 Product Description

3.1 Serial number & product name

Refer to the product nameplate.

3.2 Labels and safety signs



Safety signs that are missing or illegible must be replaced before the machine is used.

According to **Fig. 1**.

1. Safety sign
"Use Hearing Protection"
2. Nameplate
3. Label showing W3 certification (IFA)
4. Label for marking actuator for compressed air purging
5. Label on actuator for compressed air purging
6. Fumex logo

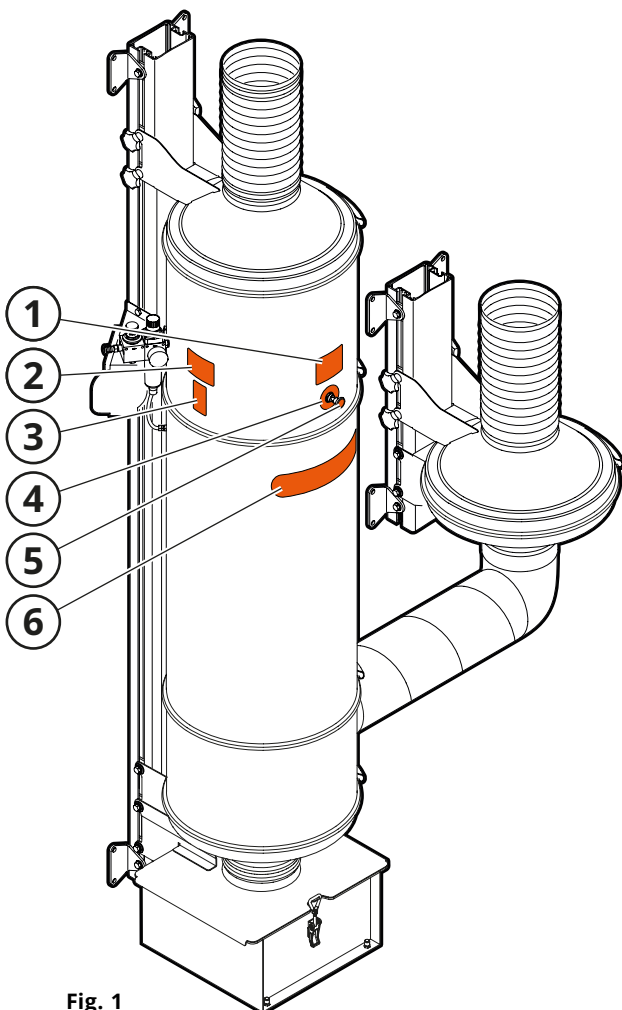
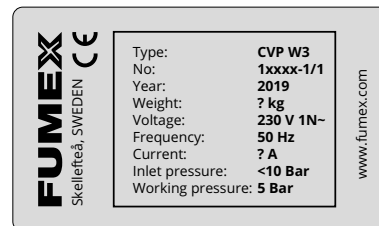

Fig. 1



1



2



3

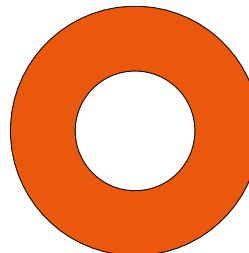

4



5



6

3.3 Areas of Use

Filter unit CVP is intended for cleaning of dust-filled air. Designed for one workstation per unit.

3.3.1 Variants

The product is available in two variants:

- Filter unit CVP STD
- Filter unit CVP W3

The manual covers both variants.

3.3.1.1 Filter unit CVP STD

For filtering dry particles. The filter unit can be connected in parallel to serve multiple workstations.

3.3.1.2 Filter unit CVP W3

For filtering smoke and dust contamination from high-alloy steel welding. The filter unit can be connected in parallel to serve multiple workstations.

Meets the requirements of ISO 15012-1 regarding safety installations when welding. The filter unit is W3-certified.

3.4 Design

See Fig. 2.

- | | |
|---|---|
| 1. Pre-filter | 10. Compressed air tank |
| 2. Connection cylinder (inlet) | 11. Push button for compressed air cleaning |
| 3. Filter housing | 12. Pressure regulator |
| 4. Outlet connection | 13. Lockable safety switch for venting and evacuation |
| 5. Straining compartment with hose connection | 14. Compressed air hose |
| 6. Dust collector | 15. Sound alarm* |
| 7. Aluminium rail | 16. Water separator |
| 8. Control housing | |
| 9. Filter | |

* Only applies to Filter unit CVP W3

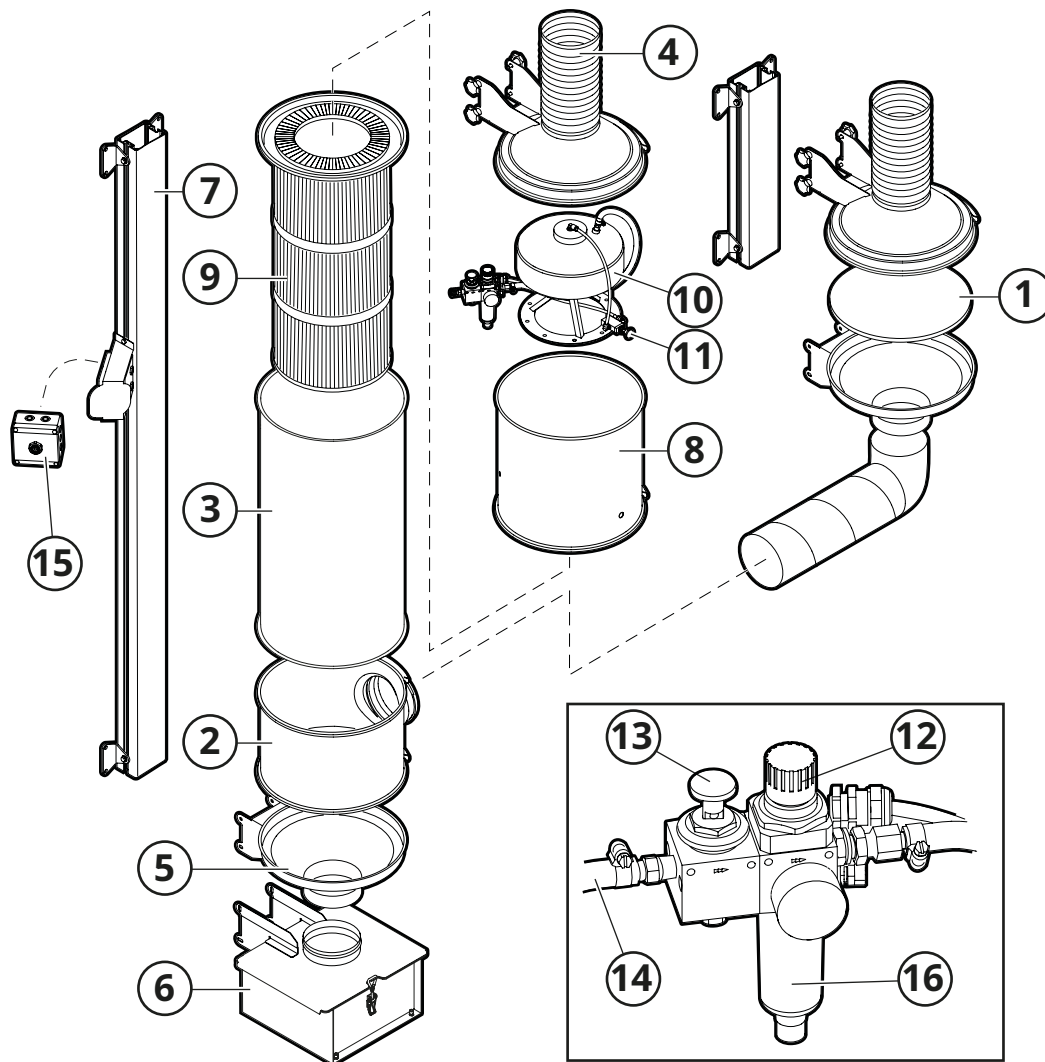

Fig. 2

3.5 Function

3.5.1 Filter unit CVP STD

Filter Unit CVP is designed for use as an individual filter or in groups. If required, the system can be expanded by placing multiple filter units beside one another which are then connected to the same exhaust air duct.

Dirty air is drawn in via Pre-filter CVM (1, **Fig. 3**), which minimises sparks. The air then passes through the inlet (2) and is purified through the vertically mounted filter (3). The purified air is then extracted via the outlet (4) to the exhaust fan.

Purging is carried out (5, **Fig. 4**) by manually pressing the compressed air purging button (6) so that a pulse of compressed air blows clean the filter of impurities. The pulse of compressed air comes from the blow nozzle (7). The strength of the pulse can be adjusted using the compressed air regulator (8).

After purging, the dust is gathered in the dust collector (9).

Purging restores the filter cartridge function, increasing its suction capacity and service life.

A lockable safety switch for bleeding and system purging (see pos. 13, **Fig. 2**) with quick-bleed valve and filter regulator is used to ensure that servicing can be carried out safely.

3.5.2 Filter unit CVP W3

In addition to the function described above, Filter Unit CVP W3 filters more than 99 % of smoke and dust contaminants from the welding of high-alloy steels, such as steel with a nickel and chromium content of 30 %.

An audible alarm (10, **Fig. 4**) signals when the air flow is less than 600 m³/h, indicating that the machine's suction capacity is insufficient.

To minimise the risks associated with dust handling, place Dust Bag CFE PSW3 in the dust collector to make handling easier when emptying the dust collector. Dust Bag CFE PSW3 is secured to the outside bag with Magnet MG-80 to ensure that the bag is not sucked into the filter housing and that the dust remains in the dust collector.

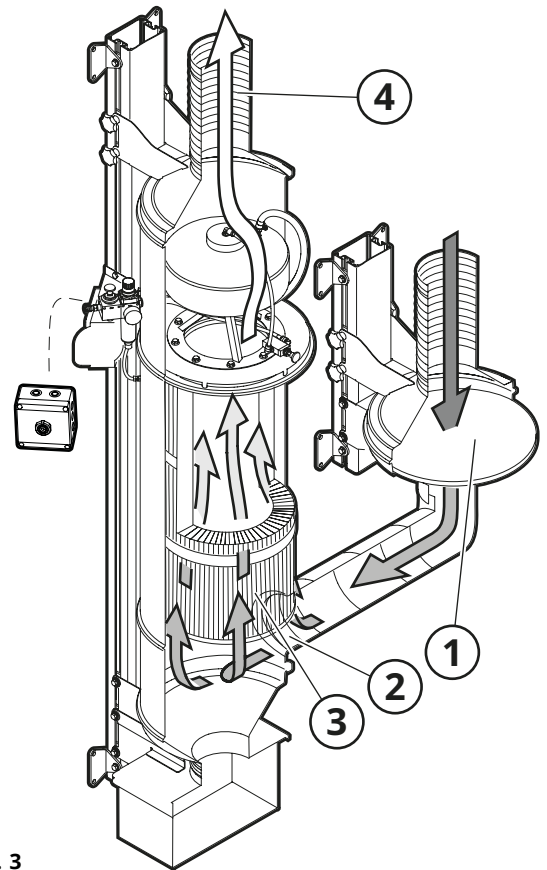

Fig. 3

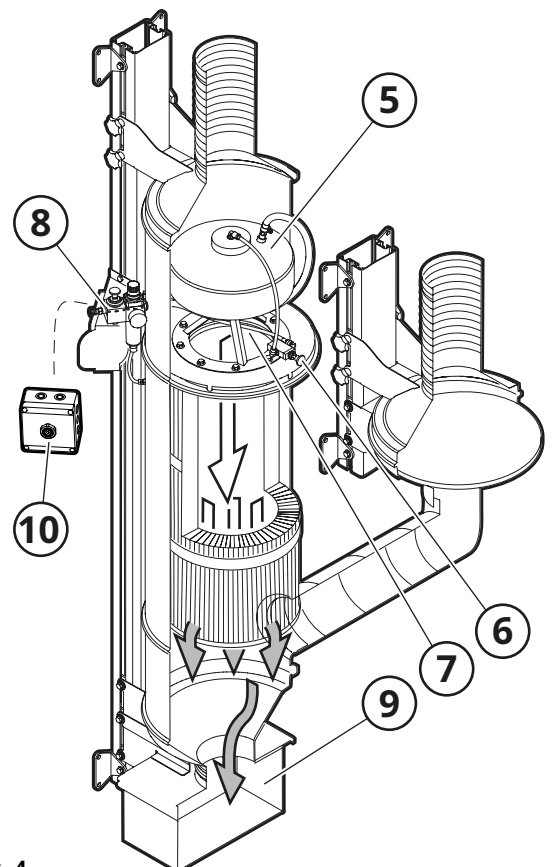

Fig. 4

4 Preparation for use

4.1 Transport & storage



Protect the machine and its parts from rain, snow, aggressive atmospheres and other harmful effects.

4.2 Electrical equipment*



Faults in the electrical system must be rectified immediately.

Check all external wires as well as the power switch, light, timer and motor for visible external damage. Repair any damage immediately.

* Only applies to Filter unit CVP W3

4.3 Assembly



When mounting the aluminium rail, a wall - along with bolts and nuts - that can manage the weight of the product, is required. Take consideration to the filter increasing in weight during its service life (both the dust collector and the filter, individually).

National rules and regulations must always be adhered to during assembly work.

4.3.1 Unpacking

1. Remove the packaging.
2. Check for any damage and missing parts. Contact a local Fumex representative directly if there is damage or parts are missing.
3. Dispose of the packaging material according to local recycling regulations.

4.3.2 Service area



Prior to installation, it is important to ensure that there is adequate room around the filter for servicing and repair. See **Fig. 5**.

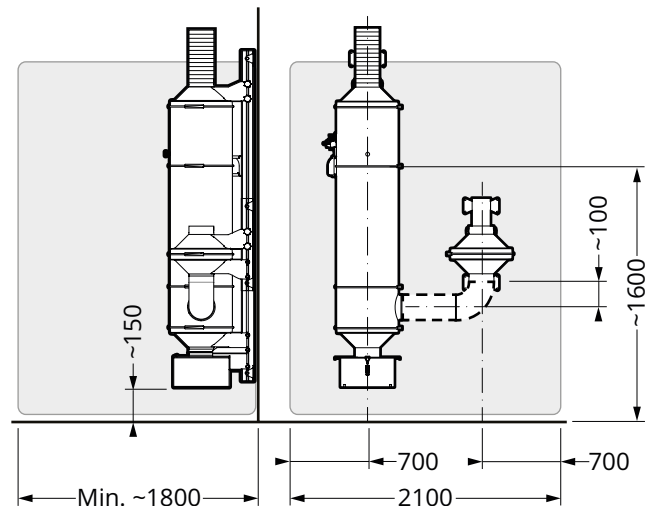

Fig. 5

4.4 Installation

4.4.1 Duct dimensioning

W3

The duct system must consist of a standardised so-called Spiro duct system.

One filter unit



Fumex recommend **Fan FB 110**.

W3

Filter Unit CVP W3 is W3 certified with Fan FB 110 for one unit. Fumex only provides a warranty for product's in a certified configuration.

For airflows up to 1100 m³/h, the duct must have a diameter of at least Ø160 mm. For airflows over 1100 m³/h, the duct must have a diameter of at least Ø200 mm.

Two filter units



Fumex recommend **Fan FB 220**.

W3

Filter Unit CVP W3 is W3 certified with Fan FB 220 for two units. Fumex only provides a warranty for product's in a certified configuration.

Where the duct serves both filter units: For airflows up to 2000 m³/h, the duct must have a diameter of at least Ø200 mm. For airflows over 2000 m³/h, the duct must have a diameter of at least Ø250 mm.

4.4.2 Pneumatics

See schematics as shown in section **10.3 Circuit diagram pneumatics**.

4.4.3 Electronics



Equipment supplied with high voltage must always be fitted with a safety switch.



The choice of cable and cable cross-section must comply with the national requirements that apply to fixed installations.

W3

Pressure gauge CV BW3 is supplied with 230 V 1N ~, 6A and installed according to the circuit diagram.

See the schematics for the selected product in section **10.4 Circuit diagram electronics**.

5 Commissioning

5.1 Before start-up

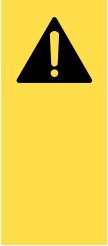
 Points 1 and 2 may only be performed when the machine is locked. The machine must be locked by locking the electrical operating switch and the pneumatic safety switch in their Off positions; see **Fig. 6**. Place warning labels on the switches.

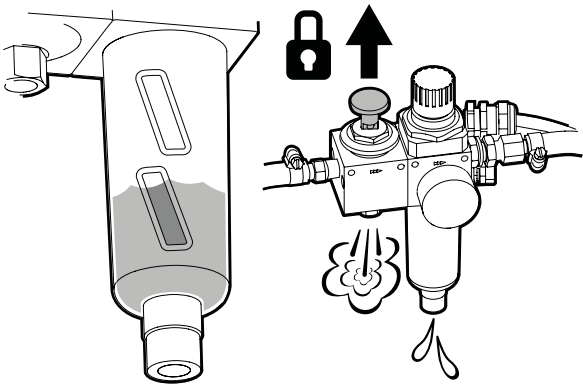



Fig. 6

1. Inspect the filter and ventilation ducts thoroughly for any foreign objects. Remove any such objects immediately.
2. Make sure the gaskets and connections on the filter and ventilation ducts are tight.

5.2 Start-up

 Any faults must be rectified before turning on the power.
 Start-up of the system may only be performed by properly trained personnel!

1. Open the compressed air supply.

 Operating pressure must be 5 bar in the compressed air system.

2. Check the pressure in the compressed air system.
3. Start the fan and check the rotational direction.
4. Turn off the fan.

 Note! Sudden noise! Use ear protection and safety glasses, warn others nearby prior to manual cleaning!

5. Check that the pressure valve opens and closes; conduct manual cleaning by pressing the push button per **Fig. 7**.

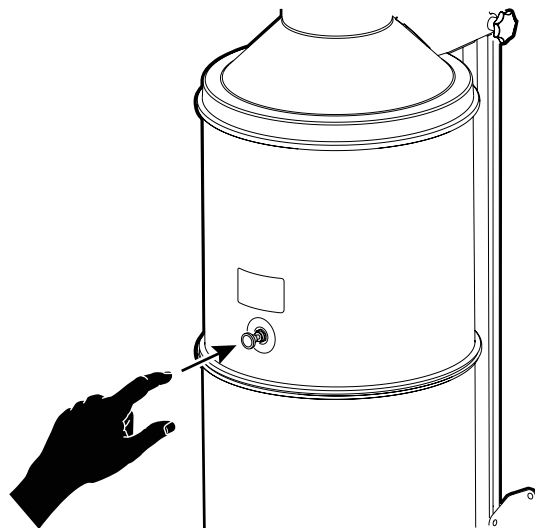

Fig. 7

5.3 Pre-coating*

i Do not clean with compressed air immediately after pre-coating has been applied so as not to dislodge the protective coating.

The pre-coat can be ordered together with spare filter. Part number: CF PRECOAT_S - Standard

W3 Pre-coating should not be performed on Filter Cartridge CFS 149W3, mounted in CVP W3.

To attain maximum service life for the filter cartridges, these must usually be pretreated. Pretreatment or "pre-coating" consists of introducing particles into the filter cartridge as follows:

1. Disconnect the dust collector and divide the particles equally between the total modules (1 kg/cartridge).
2. Start the fan at full speed and extract all the dust. Dispense the powder in an even flow so that the suction rate is approximately 20 sec/1 kg, see **Fig. 8**.
3. The filter is now ready for operation.

* Only applies to Filter unit CVP STD

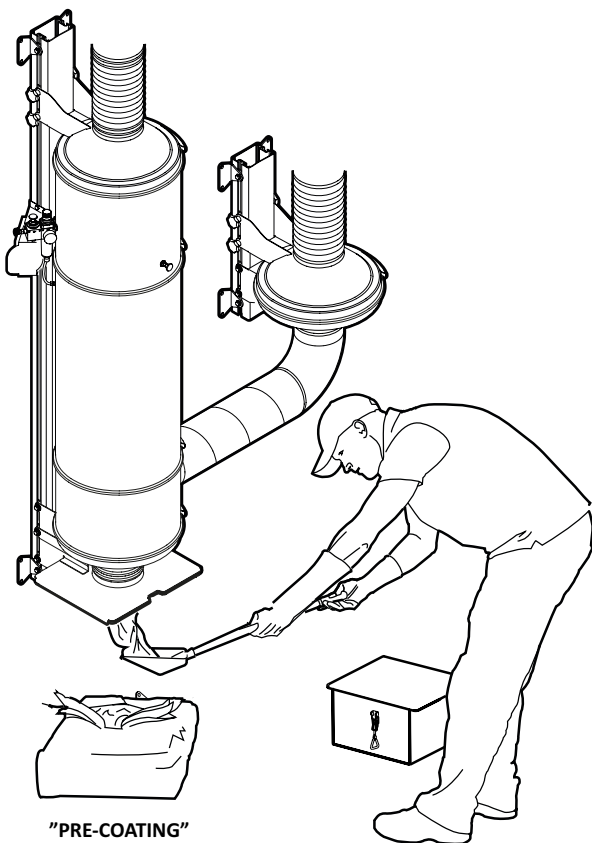

Fig. 8

6 Operation

i Note that electronic equipment is always sensitive to static electricity, high humidity, high temperature, and grid disruption.

6.1 Control panel

See **Fig. 7**.

6.2 Manual cleaning

! Use ear protection when cleaning filters with compressed air and warn any others nearby for loud noise.

i Manual cleaning is always carried out with the fan switched off, in order for the particles to fall off from the filter media into the dust collector.

Remember to empty the dust collector as necessary where the particles are gathered during cleaning.

After a period of use, the filter media will become blocked and a manual cleaning is necessary to avoid poor performance and the risk of the cartridge filter collapsing and rupturing.

Procedure for manual cleaning

1. Make sure that the fan is switched off.
2. Perform manual compressed air purging by pressing the push button three times at ten-second intervals, as shown in **Fig. 7**.
3. Start the fan and check the air flow at the source of extraction.

When the Sound Alarm signals**:

Hazardous filter load. The alarm signal indicates that the air flow probably is below the minimum limit value. Perform manual cleaning until the sound alarm stops.

If the sound alarm wont stop after repeated cleaning, change filter cartridge.

** Only applies to Filter unit CVP W3

7 Troubleshooting



Troubleshooting with the power switched on may only be carried out by a licenced electrician.

7.1 Troubleshooting guide

The troubleshooting guide contains information for identifying faults which are simple to rectify. Always perform the troubleshooting procedures before contacting FUMEX.

TROUBLESHOOTING GUIDE		
Symptom	Possible cause	Recommended action
1. Poor airflow.	Cleaning not performed.	Perform the manual filter cleaning procedure (refer to Section 6.2 Manual cleaning).
	Filter cartridge full.	Replace filter cartridge.
	Pre-filter full	Clean or replace pre-filter.
	Fan defective.	Check fan suction capacity.
	Duct system clogged.	Clean the duct system interior.
	Hole in duct system.	Replace defect duct.
2. Material accumulates in the straining compartment.	Wet dust is building up on the walls.	Evacuate drier dust.
	Dust collector full.	Check the level in the dust collector, and empty it if necessary.
3. Visible dust on the clean side of the filter unit.	Defective filter cartridge.	Replace the defective filter cartridge.
	Filter cartridge incorrectly installed.	Install the filter cartridge correctly.
	Incorrect filter material is being used.	Contact the customer service/servicing department.
4. Leakage between sections.	Tension ring incorrectly fixed.	Mount the tension ring correctly.
	Seal damaged.	Check the seal and replace if necessary.
5. Dust emitted from the suction opening during and/or after purging.	Damper missing.	The damper must be installed before the filter unit.
	Damper open.	Close damper.
	Defective damper.	Replace damper.
6. Ineffective cleaning.	Filter cartridge full.	Replace filter cartridge.
	Filter cartridge incorrectly installed.	Install the filter cartridge correctly.
	Pneumatic pulse too weak.	Check the compressed air supply.
		Check that the operating pressure in the compressed air system is at 5 bar.
Defective valve.	Check and valve and replace if necessary.	

8 Maintenance



Check all couplings for compressed air after maintenance is completed.



Please remember that only original spare parts may be used.

Make sure that all moving parts are secured to prevent unintentional movement.

8.1 Cleaning

The product should be cleaned with clean cloths and neutral detergents to avoid damage.

8.2 Maintenance schedule



Depending on the changing operating conditions between the different systems, the intervals for recommended maintenance may differ. Users should therefore determine their own maintenance intervals.

The checklist for maintenance is designed for normal use of the machine. The recommended intervals are approximate and refer to the time after the first start-up.

FUMEX recommends the following maintenance schedule:

MAINTENANCE SCHEDULE				
Interval	Item	Inspection module	Maintenance instructions	Date
When necessary	1.1	Filter unit CVP	Clean exterior. See section 8.1 Cleaning .	
	1.2	Pre-filter	Clean exterior. See section 8.1 Cleaning .	
	1.3	Pneumatics	Empty the condensation water that has been gathered in the water separator.	
Daily	2.1	Dust collector	Check the level and empty if necessary.	
Once a month	3.1	Filter cleaning	Check functionality by purging the filter (refer to Section 6.2 Manual cleaning).	
	3.2	Suction capacity	Inspect wire mesh filter in Pre-filter CVM. Clean or replace if necessary.	
	3.3	Tension rings	Make sure there are no leaks.	
Every three months	4.1	Cartridge filter	Check for dust at the outlet in the clean section. Rectify if necessary.	
	4.2	Pneumatics	Check for any wear at the hose connections as well as the tightness against the filter housing.	
Every six months	5.1	Electrical equipment*	Check all electrical equipment for visible external damage. Replace if necessary.	
	5.2	Filter housing	Check for leaks, damage and wear.	
	5.3	Duct connections	Make sure there are no leaks.	
	5.4	Dust collector	Make sure there are no leaks.	
Once a year	6.1	Duct system	Check the dust build-up and clean if necessary.	

* Only applies to Filter unit CVP W3

8.3 Replacing the filter cartridge



Changing filter requires two people.

It is important that no dust contaminates the surrounding environment. If dust has escaped and reaches the ground, it must be cleaned up immediately with an industrial vacuum cleaner equipped with HEPA-filter.



Check that the filter cartridge seal has not become damaged. Replace the seal if necessary.

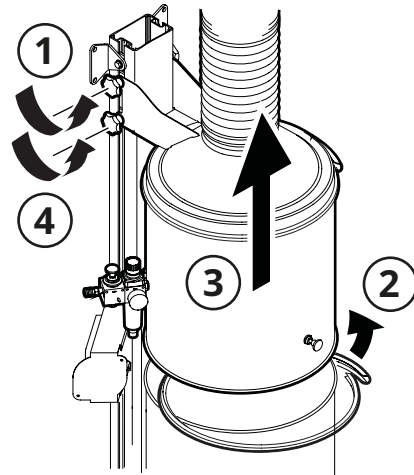

Fig. 9

8.3.1 Filter unit CVP STD

1. Shut down the system and empty the air tank (see section **8.6.1 Evacuate pressure tank**).
2. Loosen the four fixation (1, **Fig. 9**) knobs for the outlet and remove the tension ring (2) between the filter housing and control housing.
3. Now push the control housing up (3) and secure it in the aluminium rail (4) so that it is firmly in place.
4. Remove the tension ring (5, **Fig. 10**) between the filter housing and the connection cylinder.
5. Lift the filter housing and place on a flat surface (6).
6. Lift out the filter from the filter housing (7).
7. If necessary, clean the filter housing.
8. Insert a new filter into the filter housing (**Fig. 11**).
9. Refit the filter housing with the new cartridge filter, seal and connect all components that were removed during dismantling.
10. Follow the instructions for pretreatment of the filter cartridge in section **5.3 Pre-coating**.
11. Clean the area around Cartridge Filter CVP with an industrial vacuum cleaner equipped with HEPA filter.

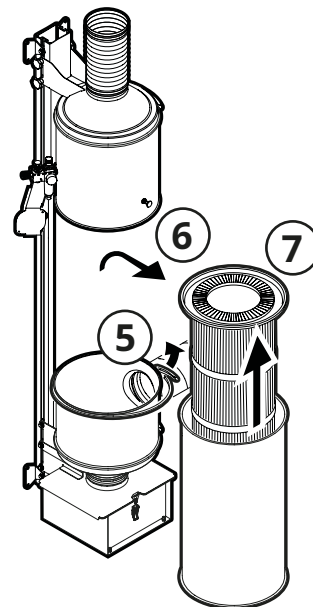

Fig. 10

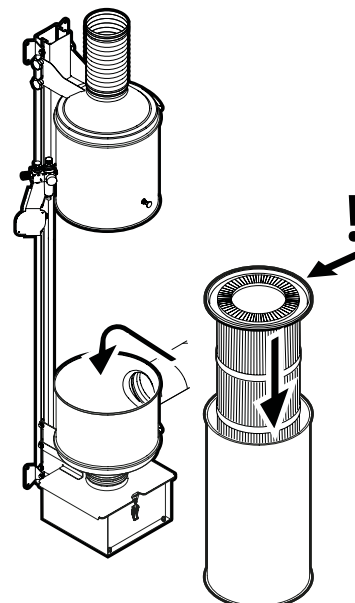

Fig. 11

8.3.2 Filter unit CVP W3

1. Shut down the system and empty the air tank (see section 8.6.1 Evacuate pressure tank).
2. Loosen the four fixation knobs (1, Fig. 9) for the outlet and remove the tension ring (2) between the filter housing and control housing.
3. Now push the control housing up (3) and secure it in the aluminium rail (4) so that it is firmly in place.
4. Remove the tension ring (5, Fig. 10) between the filter housing and the connection cylinder.
5. Place Filter bag CFE PCW3 (6, Fig. 12) over the filter housing so that it covers all the way down to the connection cylinder.
6. Lift the filter housing with Filter bag CFE PCW3, turn it upside down and place on a flat surface (7).
7. Lift out the filter housing from Filter bag CFE PCW3 (8, Fig. 13) so that only the cartridge filter remains; seal the package (9).
8. If necessary, clean the filter housing.
9. Turn back the filter cylinder, place on a flat surface and insert a new Cartridge filter CFS 149W3 (Fig. 14).
10. Refit the filter housing with the new cartridge filter, seal and connect all components that were removed during dismantling.
11. Clean the area around Cartridge Filter CVP with an industrial vacuum cleaner equipped with HEPA filter.

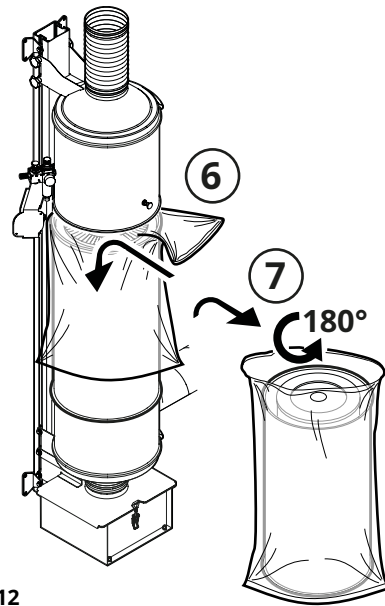

Fig. 12

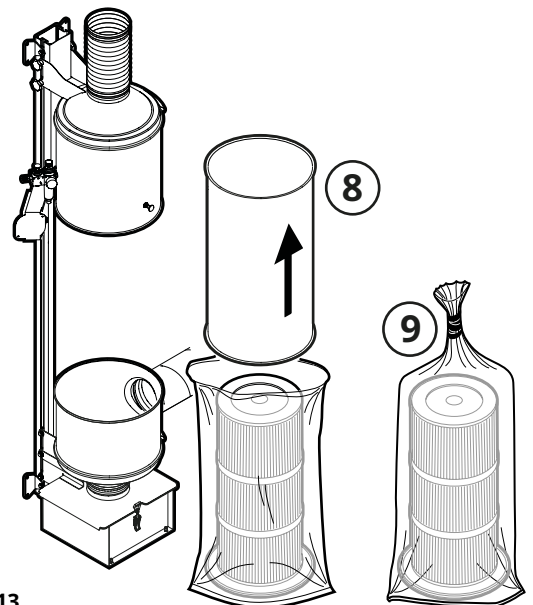

Fig. 13

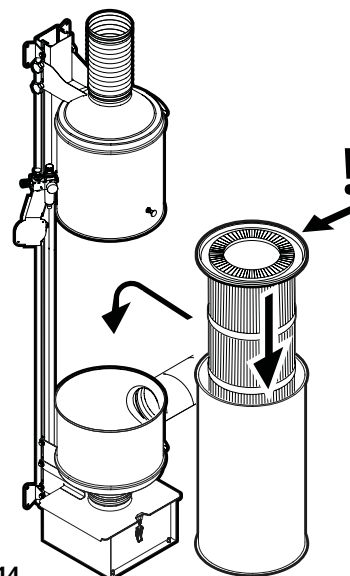
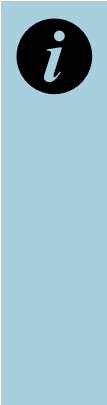

Fig. 14

8.4 Emptying the dust collector



It is important that no dust contaminates the surrounding environment. If dust has escaped and reaches the ground, it must be cleaned up immediately with an industrial vacuum cleaner equipped with HEPA-filter.



The dust collector should be emptied regularly to the dust collector from becoming too heavy for normal manual handling (max. 20 kg).

It is important that the dust collector is correctly mounted so that there is a tight fit. This can be adjusted with the eccentric lock.

Check that the dust collector seal has not become damaged. Replace the seal if necessary.

8.4.1 Filter unit CVP STD

1. Turn off the system.
2. Remove the eccentric lock and pull out the dust collector.
3. Dispose of waste in the dust collector according to applicable laws and regulations.
4. If necessary, clean the dust collector.
5. Push in the dust collector and secure it with the eccentric lock.
6. Clean the area around Cartridge Filter CVP with an industrial vacuum cleaner equipped with HEPA filter.
7. Start the system.

8.4.2 Filter unit CVP W3

1. Turn off the system.
2. Remove the eccentric lock and pull out the dust collector.
3. Seal Dust bag CFE PSW3 with tape or similar method and lift it up out of the collector.
4. Dispose of waste in the dust collector.
5. If necessary, clean the dust collector.
6. Carefully fit a new Dust bag CFE PSW3 in the dust collector (**Fig. 15**).

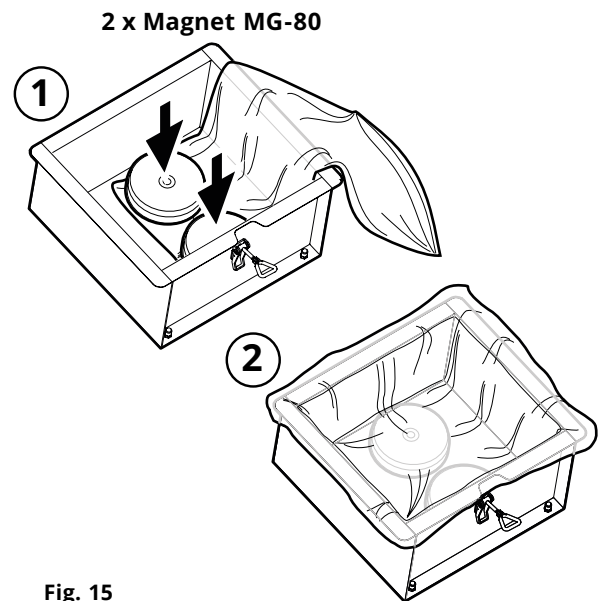

Fig. 15

7. Push in the dust collector and secure it with the eccentric lock.
8. Clean the area around Cartridge Filter CVP with an industrial vacuum cleaner equipped with HEPA filter.
9. Start the system.

8.5 Replacing/cleaning the Prefilter CVM

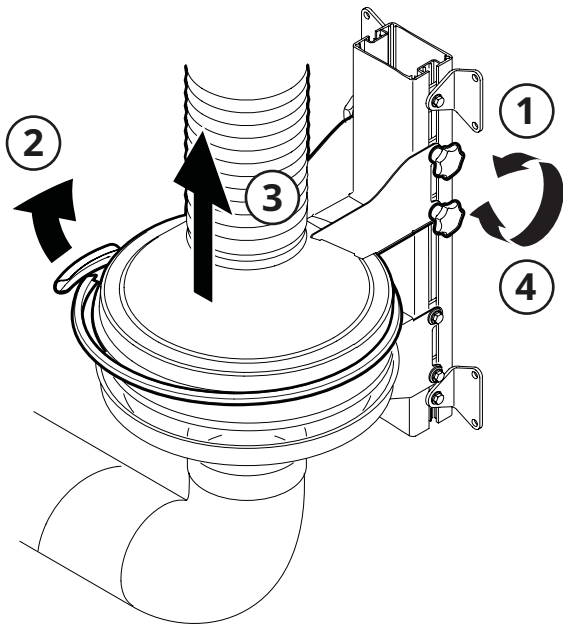

Fig. 16

8.5.1 Filter unit CVP STD

1. Shut down the system and purge the compressed air tank (see Section 8.6.1 Evacuate pressure tank).
2. Loosen the knobs (1, Fig. 16) on the top cone and the tension ring (2).
3. Then slide the top cone (3) up and lock it firmly in place in the aluminium rail (4).

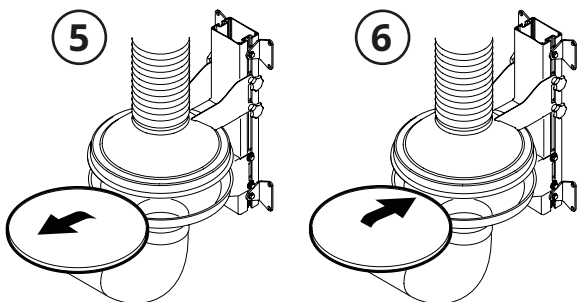

Fig. 17

4. Remove the wire mesh filter from the bottom cone (5, Fig. 17) and dispose of or clean with neutral detergents under lukewarm tap water.
5. If necessary, clean the interior of the pre-filter housing.

6. Place the new or cleaned wire mesh filter in the bottom cone (6) and seal and connect all the parts that were loosened during disassembly.
7. Clean the area around Pre-filter CVM with an industrial vacuum cleaner equipped with HEPA filter.

8.5.2 Filter unit CVP W3

1. Shut down the system and purge the compressed air tank (see Section 8.6.1 Evacuate pressure tank).
2. Loosen the knobs (1, Fig. 16) on the top cone and the tension ring (2).
3. Then slide the top cone (3) up and lock it firmly in place in the aluminium rail (4).

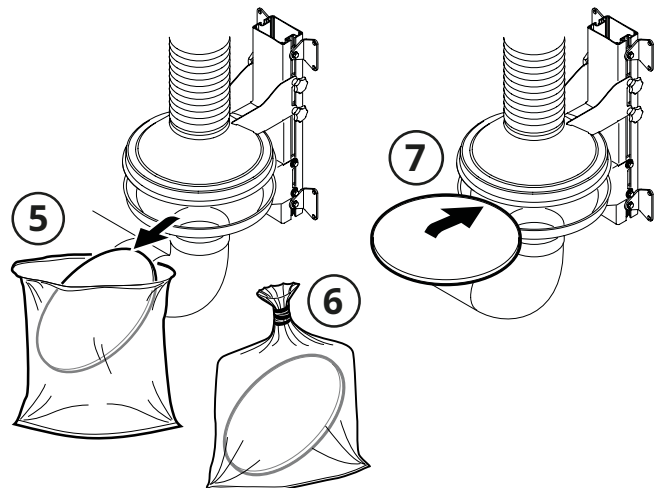

Fig. 18

4. Lift the wire mesh filter out of the lower cone and insert Filter Bag CFE PCW3 (5, Fig. 18). Seal the bag (6) and dispose of or clean the wire mesh filter with neutral detergents under lukewarm tap water.
5. If necessary, clean the interior of the pre-filter housing.
6. Place the new or cleaned wire mesh filter in the bottom cone (7) and seal and connect all the parts that were loosened during disassembly.
7. Clean the area around Pre-filter CVM with an industrial vacuum cleaner equipped with HEPA filter.

8.6 Compressed air



During service or any other type of maintenance, the safety switch must be locked and the main system shut off.

8.6.1 Evacuate pressure tank

1. Pull the lockable safety switch upward and the pressure tank evacuates (**Fig. 19**).

8.6.2 Evacuate water separator

1. Regularly check the water level in the water separator. When the water level reaches the marking on the collection cup;
2. pull the lockable safety switch upwards, draining the water separator as the pressure tank is evacuated (**Fig. 19**).

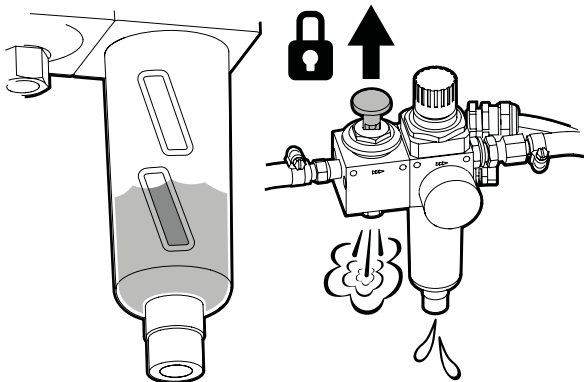

Fig. 19

9 Decommissioning

9.1 Final decommissioning/ disassembly/disposal

Final decommissioning and disassembly of the product may only be done by authorized personnel wearing protective gear. The handling and correct removal of the various types of materials must be in accordance with the applicable legal requirements.

Please contact FUMEX if you have any questions about the various types of waste.

10 Technical information

10.1 Dimensional drawing (mm)

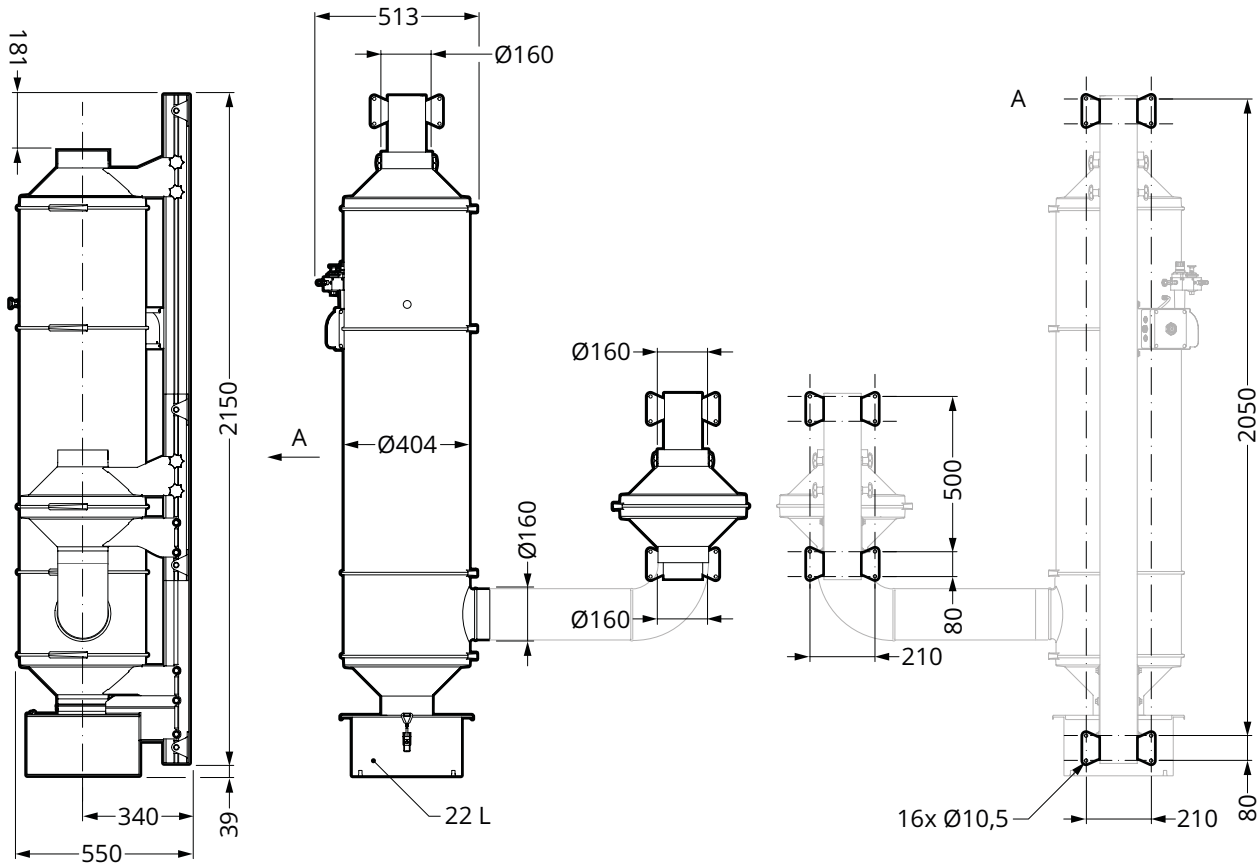

10.2 Technical data

Weight:	CVP STD	CVP W3	Pre-filter CVM
	44 kg	44 kg	8 kg

Material

Filter housing: Painted sheet metal
 Mounting profile: Anodised aluminium
 Mounting brackets: Painted sheet metal

Electronics*

Voltage: 230 V 1~
 Frequency: 50 Hz
 Power: 1.5 kW
 Current: 3.1 A
 Enclosure class: IP 54

Pneumatics

Incoming air pressure: <10 Bar
 Recommended operating pressure: 5 Bar
 Compressed air quality: Klassifikation 4 (ISO 8573.1)
 Consumption per pulse: 7 l
 Pressure in exhaust valve: 350 kPa

Filtration

Number of filter cartridges: 1 st
 Filter area: 14 m²
 Recommended air flow: 1100 m³/h
 Minimum airflow: 600 m³/h

Filter	CVP STD	CVP W3
Type of filter cartridge:.....	CFS 149	CFS 149 W3
Material:.....	Polyester	Polyester/PTFE
Filtration efficiency (according to EN-60335-2-69):	99,9%	99,9%
Dust class:	M(BIA)	M(BIA)
Load/m ² during welding:.....	80 ±5 m ³ /h/m ²	80 ±5 m ³ /h/m ²
Filter class (EN 1822-1:2019):	HEPA 13	HEPA 13**
Maximum negative pressure over the cartridge:	1800 Pa	1800 Pa
Max. load:.....	2500 Pa	2500 Pa

Temperature limits

Operating temperature:..... +5 °C till +60 °C
 Ambient temperature: +5 °C till +50 °C
 Transport & storage temperature:.. -25 °C till +60 °C
 Max. humidity:..... 80 %

Alarm limit for cleaning

Audible alarm:..... 1500 Pa

Sound level

Audible alarm SPL: 85 ±3 dB
 Purging L_{pA}***: 77 dB (A)

** Filter material penetration rate is 0.02%, Class M (EN 60335)
 *** A-weighted emission sound pressure level at the control panel.
 Uncertainty data, KpA=2 db (A).

* Only applies to Filter unit CVP W3

10.3 Circuit diagram pneumatics

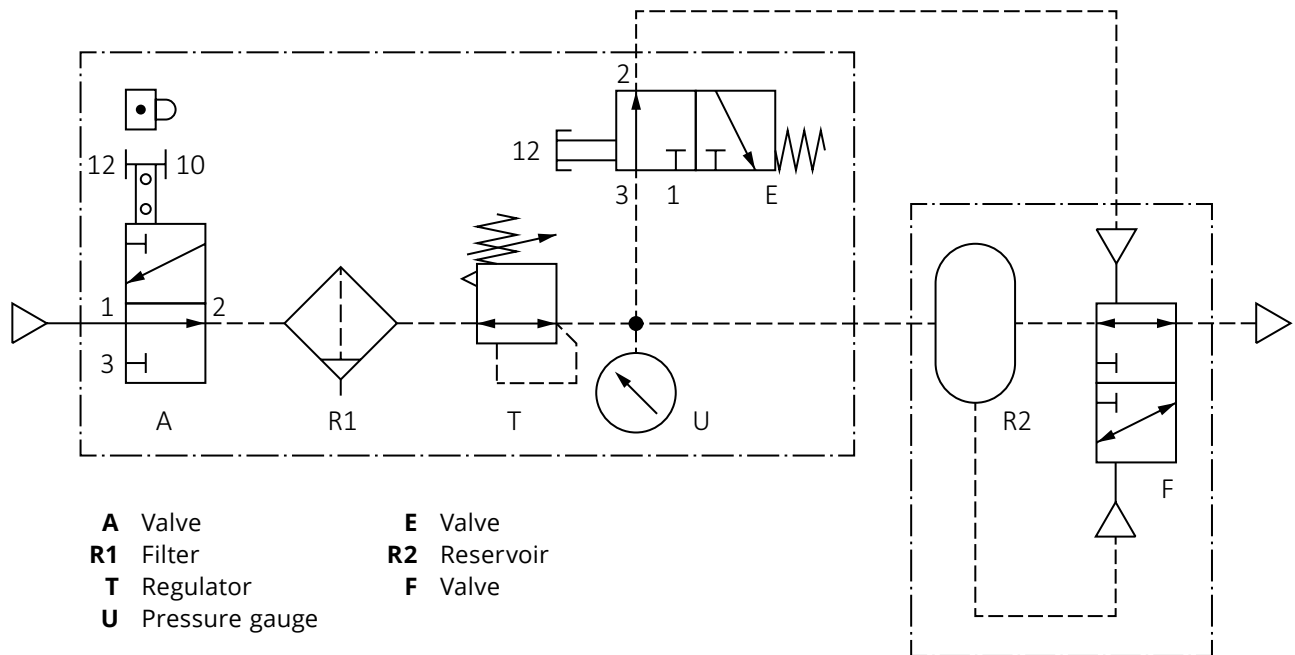

10.4 Circuit diagram electronics

10.4.1 Filterunit CVP W3

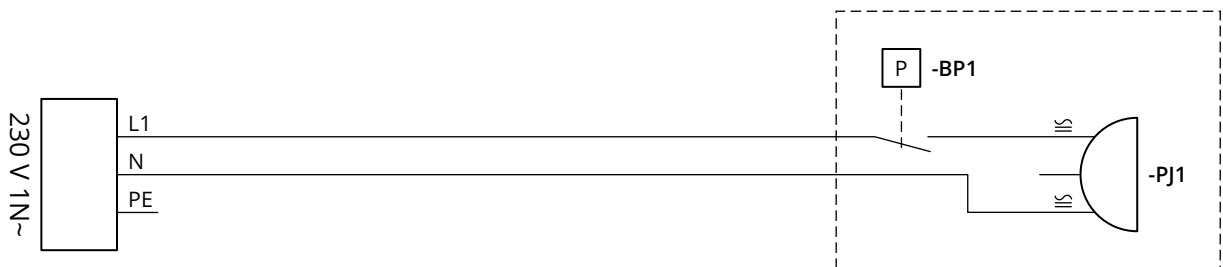

10.5 Exploded-view drawing



11 Accessories & Spare Parts

Filter cartridge CFS 149

Art.no. 112145

Filter cartridge for use with normal loads, such as welding and stone dust. The filter is made of a polyester material and is protected by expanded metal on the inside.

Filter cartridge CFS 149W3

Filter cartridge for use upon normal load in ISO 15012-1, Health and safety in welding and allied processes. The filter consists of a corrugated polyester material coated with a teflon membrane that is protected by expanded metal on the inside.

Buying CFS 149W3 includes Filter bag CFE PCW3

Fig. 20

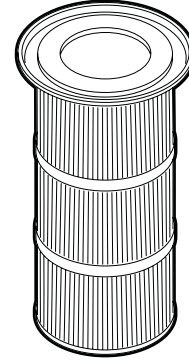

CMF PCW3

Filter bag for contact-free filter cartridge replacement.

CMF PSW3

Dust bag for contact-free dust collector emptying.

Fig. 21

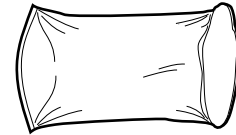

Magnet MG-80

Magnet for securing of Dust Bag CFE PSW3.

Fig. 22

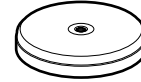

Manometer CV BW3

Manometer for indicating the maximum load of the filter. Displays the pressure drop across the filter cartridge and indicates when the filter cartridge needs cleaning.

Fig. 23



Sound alarm CV LW3

Sound alarm for indicating too low air flow.

Fig. 24



Wire Mesh Filter CVM W3

Filter for Pre-filter CVM. Reduces sparks and the risk associated with spark-filled air. When purchasing Wire Mesh Filter CVM W3, Filter Bag CFE PCW3 is included.

Fig. 25

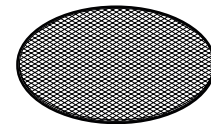

Cartridge Filter CVP Sealing Ring

For fitting to Cartridge Filter CVP. Minimises leakage.

Fig. 26

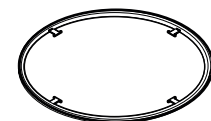

Dust Collector Sealing Strip

For fitting to dust collectors. Minimises leakage.

Fig. 27

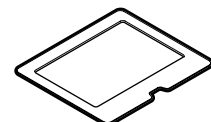

12 Notes

FUMEX SUPPLIES EXTRACTION ARMS · VEHICLE EXHAUST EXTRACTION · FANS · FILTERS · CONTROLS · WORKSHOP EQUIPMENT

FUMEX

Verkstadsvägen 2, 93161 Skellefteå, Sweden • Tel.: +46 910-361 80 • Fax: +46 910-130 22 • E-mail: info@fumex.se
www.fumex.com